

CARE & INSTALLATION INSTRUCTIONS

Pre-Installation

- Store in a dry location, under cover where possible, to protect against damage.
- Do not rack frames out of square.
- Prevent exposure to moisture particularly pooling or ponding.
- Do not remove bands from Double Hung Windows until after installation.

Care and Maintenance

- Keep wet cement, mortar and brick cleaning acid from contact with timber or aluminium before, during and after installation.
- If accidentally splashed, wash off immediately with clean water, otherwise permanent staining or damage may occur, voiding the warranty.
- Do not use acid to remove mortar stains on window frames.
- Hose down brick work to remove residual cleaning acid which may leach out and cause damage to the finish later.
- Do not place windows directly onto green concrete slabs.
- Keep the tracks of sliding windows and doors clear of sand and cement droppings.
- Do not use window frames to support planks or temporary scaffolding.
- Clean up when the job is complete with mild detergent and rinse with clean water.

Glass

- To clean simply wipe over the surface with a few drops of methylated spirits on a damp cloth, then polish the surface dry with a lint free cloth.
- Ensure that all cleaning cloths are free from any abrasive substances.
- Never remove abrasive materials such as mortar from the glass with a scraper. (To clean, flood with water and dab with a sponge. Don't scrub with sponge or scratching will occur.)
- Avoid causing extreme temperature changes as this may lead to thermal fracture of the glass (i.e. do not direct hot or cold water onto glass).

Locks and Catches

- Keep locks and catches clean and free from blind cords and any other interference which may prevent proper operation.

Painting

- Timber windows must have a first coat of an appropriate paint, oil or stain applied within 30 days of delivery.
- Fill nail recesses, lightly sand and clean immediately prior to the application of further coats.
- Re-prime immediately if primer coat is removed during installation.
- Paint manufacturers instructions must be followed in the application of all subsequent coats of paint.
- It is recommended to use light colours on all timber products.
- Do not paint over weatherseals.
- Primed products need to be lightly sanded before the undercoat and top coats are applied. Primer is not a substitute for an undercoat.

Adjustments

- All products should be adjusted as required to maintain correct performance.
- Adjustment instructions are supplied with the product.

Bifold Window Pre-Installation Instructions

- 1 A structural beam or lintel is recommended to be fitted above all Bifold Window units.
- 2 The lintel must be able to support the weight of the Bifold Window unit. Bifold Window units weigh approximately 22kg per m².
FOR EXAMPLE A 1500mm x 2500mm Bifold Window will weigh 1.5m x 2.5m x 22kg = 82kg.
NOTE Twin glazing will double the calculation.
- 3 Failure to comply with instructions may result in poor operation of the unit and could void the warranty.

Bifold Window Installation Instructions

- 1 Fit flashing to sill and where required to stiles and head.
- 2 The complete unit must be installed square, plumb and level. Panels will not operate successfully with a bowed sill or a dropped head.
- 3 It is highly recommended that the Bifold Window head is fixed to a suitable lintel above. Fix the Bifold Window head to the lintel as per drawing below.

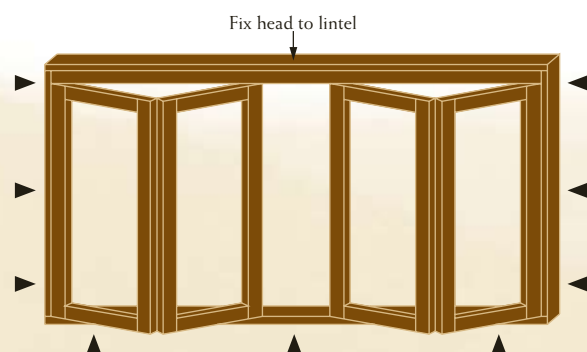
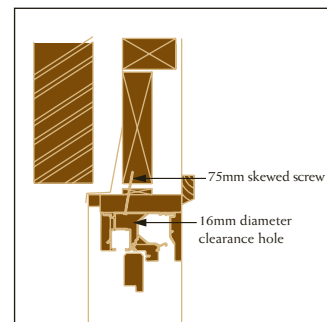

The Bifold Window head extrusion has been pre-drilled with a 16mm clearance hole and a 5mm screw hole in the centre of the track. Use a 75mm screw to screw the Bifold Window head to the lintel.

NOTE: AS2047 sets out the requirements for installation of timber windows in buildings. It is the responsibility of the installer to properly adjust windows and doors as per instructions.